

**TRUCK LOADS ON PIPE  
BURIED AT SHALLOW DEPTHS**

**DIPRA**  
**DIPRA**  
**DIPRA**  
**DIPRA**

**®**

# TRUCK LOADS ON PIPE BURIED AT SHALLOW DEPTHS

By  
**Richard W. Bonds, P.E.**  
**DIPRA Research/Technical Director**

Depth of cover less than 2<sup>1</sup>/<sub>2</sub> feet is generally not recommended under roads and highways due to the possibility of high dynamic loading. Such loadings could result in damage to the pavements and/or the pipes. If impact factors higher than 1.5 (which is used in this paper) are anticipated, then such should be employed. For any given project, the ultimate responsibility for the proper use of the equations and other data provided in this paper rests with the design engineer. Call DIPRA with questions before applying this paper.

The procedure for calculating truck loads on buried Ductile Iron pipe is provided in ANSI/AWWA Standard C150/A21.50.<sup>1</sup> This procedure is based on the teachings of Merlin Spangler and others and utilizes the same procedures used in the venerable design standard ANSI A21.1<sup>2</sup> for Cast Iron pipe. The design method is based on two assumptions:

1. A single concentrated wheel load at the surface, and
2. Uniform load distribution over an effective pipe length of 3 feet.

The truck load on pipe buried under flexible pavement is given by Equation 5 in ANSI/AWWA C150/A21.50. It is shown below as Equation 1.

## Equation 1

$$P_t = RF \frac{CP}{bD}$$

where

- $P_t$  = Truck load in pounds per square inch  
 $R$  = Reduction factor (see Table 4 in C150/A21.50). This factor takes account of the fact that the part of the pipe directly below the wheels receives the truck superload in its full intensity but is aided in carrying the load by adjacent parts of the pipe that receive little or no load from the truck  
 $F$  = Impact factor of 1.5 (this is consistent with ASCE Manual No. 37)<sup>3</sup>  
 $C$  = Surface load factor  
 $P$  = Wheel load in pounds (for design purposes, 16,000 lbs., for a single AASHTO H-20 truck on unpaved road or flexible pavement)  
 $b$  = Effective pipe length of 36 inches  
 $D$  = Outside diameter of the pipe in inches

The surface load factor,  $C$ , is a measure of how the wheel load at the surface is transmitted and distributed through the soil to the pipe.  $C$  is given by Equation 6 in C150/A21.50 and is shown here as Equation 2.

## Equation 2

$$C = 1 - \frac{2}{\pi} \text{ARCSIN} \left[ H \sqrt{\frac{A^2 + H^2 + 1.5^2}{(A^2 + H^2)(1.5^2 + H^2)}} \right] + \frac{2}{\pi} \left( \frac{1.5 AH}{\sqrt{A^2 + H^2 + 1.5^2}} \right) \left[ \frac{1}{A^2 + H^2} + \frac{1}{1.5^2 + H^2} \right]$$

NOTE: Angles are in radians.

where

- $H$  = Depth of cover in feet  
 $A$  = Outside radius of the pipe in feet

This equation for the surface load factor,  $C$ , is derived from Holl's integration of the Boussinesq formula for vertical unit pressure, assuming the load is to be determined on a 3-foot section of pipe directly under the point load.<sup>4</sup>

Regarding the point load assumption, the following Boussinesq equation (Equation 3) gives the vertical stress at any point in an elastic medium when a point load is exerted at the surface,

## Equation 3

$$\sigma_z = \left( \frac{3P}{2\pi} \right) \left( \frac{H^3}{R_1^5} \right)$$

where

- $\sigma_z$  = Vertical stress in pounds per square inch  
 $P$  = Point load at surface in pounds  
 $H$  = Depth in inches  
 $R_1$  = Distance from the point load to the point at which the stress is to be determined in inches (See Figure 1)

## Figure 1 Single Wheelload

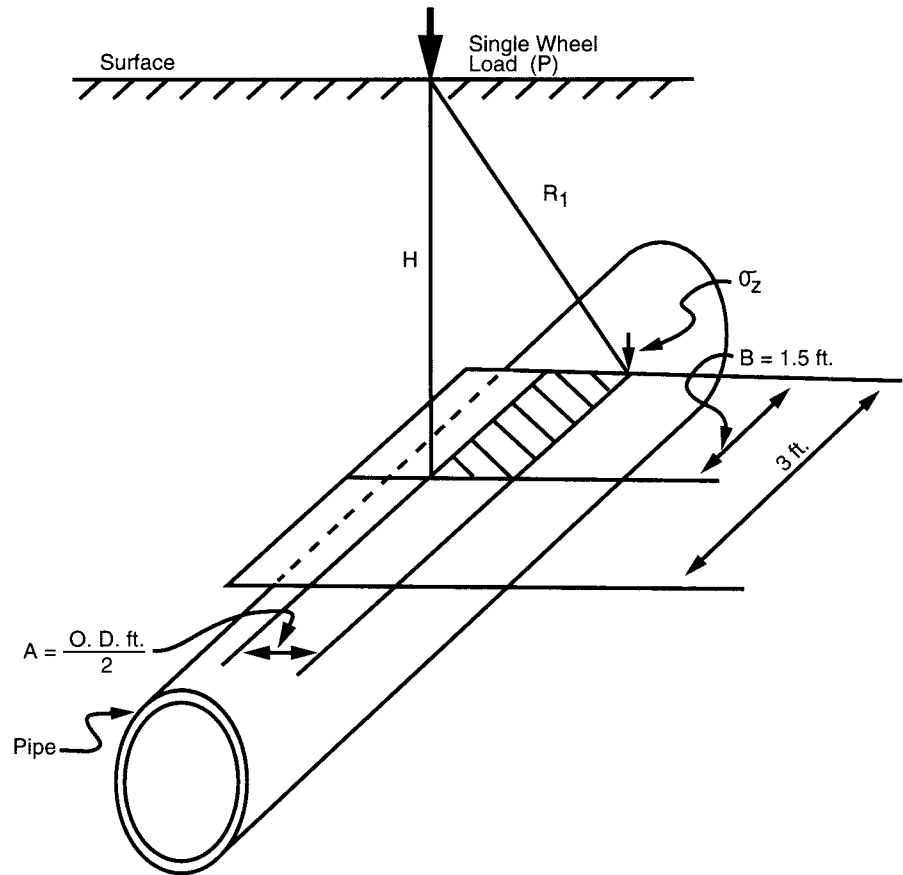

Integration of the Boussinesq equation (Equation 3) over the rectangular area over the pipe (as shown in Figure 1) results in the total load on a 3-foot section of pipe due to the point load,  $P$ , at the surface. Equation 2 is a function of this integration. The  $bD$  in the denominator of Equation 1 yields the desired units of pounds per square inch in expressing the truck load. The result thus represents an “average” pressure on the 3-foot length of pipe centered under the load.

The factors discussed above as well as other factors such as the assumed flexible pavement, the large wheel load used for design, the safety factors in the thickness design procedure, and the inherent structural strength of Ductile Iron,<sup>5</sup> lead to the conclusion that the above approach to calculating truck loading is adequate at any depth of cover. Quite obviously, the actual distributed load of a truck tire “footprint” will produce less concentrated effects on a pipe than will the assumed “point” load. The typical dual truck tire imprint may have a contact area of approximately 200 square inches.<sup>6</sup> Also, the length of pipe “effective” in carrying the load may be much greater than that assumed, particularly for large-diameter pipe. Further, in shallow cover situations under highways, the road bed stability will necessitate well-compacted fill around the pipe, which will increase its load bearing capacity.

Included herein for convenience is Table 1 (Earth Loads  $P_e$ , Truck Loads  $P_t$ , and Trench Loads  $P_v$ ), Table 2 (Surface Load Factors for Single Truck on Unpaved Road), and Table 3 (Thickness for Earth Loads Plus Truck Loads), which can be used in the same manner as Tables 1, 6, and 12 in ANSI/AWWA C150/A21.50, respectively.

## References

- 1 ANSI/AWWA C150/A21.50, *Thickness Design of Ductile Iron Pipe*.
- 2 ANSI A21.1, *Manual for the Computation of Strength and Thickness of Cast Iron Pipe*.
- 3 ASCE Manual No. 37, *Design and Construction of Sanitary and Storm Sewers*.
- 4 *Soil Engineering*, Merlin G. Spangler, 4th Edition, 1982, Chapter 16.
- 5 *Ductile Iron Pipe Design Criteria*, T.F. Stroud, P.E.
- 6 *The Asphalt Handbook*, The Asphalt Institute, Manual Series No. 4.

**Table I**  
**Earth Loads  $P_e$ , Truck Loads  $P_t$ , and Trench Loads  $P_v$ , (psi)**

Depth of cover (ft.)	3-in. pipe		4-in. pipe		6-in. pipe		8-in. pipe		10-in. pipe		12-in. pipe		14-in. pipe		16-in. pipe		18-in. pipe		
	$P_e$	$P_t$	$P_v$	$P_t$	$P_v$	$P_t$	$P_v$	$P_t$	$P_v$	$P_t$	$P_v$	$P_t$	$P_v$	$P_t$	$P_v$	$P_t$	$P_v$		
1.0	0.8	33.3	34.1	33.1	33.9	32.2	33.0	31.0	31.8	29.8	30.6	28.4	29.2	24.8	25.6	22.5	23.3	20.6	21.4
1.5	1.3	20.7	22.0	20.6	21.9	20.3	21.6	19.9	21.2	19.5	20.8	19.1	20.4	17.0	18.3	15.8	17.1	14.8	16.1
2.0	1.7	13.9	15.6	13.9	15.6	13.8	15.5	13.6	15.3	13.5	15.2	13.3	15.0	12.0	13.7	11.3	13.0	10.6	12.3

Depth of cover (ft.)	20-in. pipe		24-in. pipe		30-in. pipe		36-in. pipe		42-in. pipe		48-in. pipe		54-in. pipe		60-in. pipe		64-in. pipe		
	$P_e$	$P_t$	$P_v$	$P_t$	$P_v$	$P_t$	$P_v$	$P_t$	$P_v$	$P_t$	$P_v$	$P_t$	$P_v$	$P_t$	$P_v$	$P_t$	$P_v$		
1.0	0.8	19.0	19.8	16.6	17.4	14.2	15.0	12.1	12.9	10.6	11.4	9.4	10.2	8.4	9.2	7.9	8.7	7.4	8.2
1.5	1.3	13.9	15.2	12.6	13.9	11.3	12.6	10.0	11.3	8.9	10.2	8.0	9.3	7.2	8.5	6.8	8.1	6.4	7.7
2.0	1.7	10.2	11.9	9.4	11.1	8.7	10.4	7.9	9.6	7.2	8.9	6.6	8.3	6.0	7.7	5.7	7.4	5.4	7.1

**Table 2**  
**Surface Load Factors for Single Truck on Unpaved Road**

Depth of cover (ft.)	3-in. pipe	4-in. pipe	6-in. pipe	8-in. pipe	10-in. pipe	12-in. pipe	14-in. pipe	16-in. pipe	18-in. pipe
1.0	0.1980	0.2380	0.3329	0.4210	0.4956	0.5623	0.6195	0.6680	0.7087
1.5	0.1227	0.1482	0.2102	0.2708	0.3253	0.3773	0.4252	0.4690	0.5086
2.0	0.0828	0.1001	0.1428	0.1853	0.2244	0.2627	0.2993	0.3338	0.3661

Depth of cover (ft.)	20-in. pipe	24-in. pipe	30-in. pipe	36-in. pipe	42-in. pipe	48-in. pipe	54-in. pipe	60-in. pipe	64-in. pipe
1.0	0.7427	0.7944	0.8428	0.8714	0.8881	0.8985	0.9054	0.9082	0.9104
1.5	0.5442	0.6043	0.6700	0.7155	0.7458	0.7667	0.7818	0.7884	0.7936
2.0	0.3964	0.4504	0.5154	0.5656	0.6025	0.6303	0.6520	0.6620	0.6703

**Table 3**  
**Thickness for Earth Load Plus Truck Load**

Laying Condition											
		Type 1		Type 2		Type 3		Type 4		Type 5	
Size (in.)	Depth of Cover (ft.)	Total Calculated Thickness (in.)*	Use Pressure Class	Total Calculated Thickness (in.)*	Use Pressure Class	Total Calculated Thickness (in.)*	Use Pressure Class	Total Calculated Thickness (in.)*	Use Pressure Class	Total Calculated Thickness (in.)*	Use Pressure Class
3	1.0	0.22	350	0.21	350	0.20	350	0.19	350	0.16	350
	1.5	0.20	350	0.19	350	0.18	350	0.17	350	0.15	350
	2.0	0.19	350	0.18	350	0.17	350	0.16	350	0.14	350
4	1.0	0.23	350	0.23	350	0.22	350	0.20	350	0.17	350
	1.5	0.21	350	0.20	350	0.20	350	0.18	350	0.15	350
	2.0	0.20	350	0.19	350	0.18	350	0.16	350	0.15	350
6	1.0	0.28	-	0.27	-	0.25	350	0.23	350	0.18	350
	1.5	0.25	350	0.24	350	0.22	350	0.20	350	0.16	350
	2.0	0.23	350	0.21	350	0.20	350	0.17	350	0.16	350
8	1.0	0.32	-	0.30	-	0.29	-	0.26	-	0.20	350
	1.5	0.28	-	0.27	-	0.25	350	0.21	350	0.17	350
	2.0	0.26	-	0.24	350	0.22	350	0.19	350	0.16	350
10	1.0	0.37	-	0.35	-	0.33	-	0.30	-	0.22	350
	1.5	0.33	-	0.31	-	0.29	-	0.24	350	0.19	350
	2.0	0.30	-	0.27	-	0.25	350	0.21	350	0.18	350
12	1.0	0.41	-	0.38	-	0.36	-	0.32	-	0.24	350
	1.5	0.36	-	0.33	-	0.31	-	0.25	350	0.20	350
	2.0	0.32	-	0.30	-	0.27	350	0.22	350	0.19	350
14	1.0	**	-	0.41	-	0.38	-	0.33	-	0.26	250
	1.5	**	-	0.36	-	0.33	-	0.27	250	0.21	250
	2.0	**	-	0.32	-	0.29	300	0.24	250	0.20	250
16	1.0	**	-	0.43	-	0.40	-	0.33	350	0.27	250
	1.5	**	-	0.38	-	0.34	350	0.27	250	0.22	250
	2.0	**	-	0.33	350	0.30	250	0.24	250	0.21	250
18	1.0	**	-	0.45	-	0.41	-	0.33	300	0.27	250
	1.5	**	-	0.39	-	0.35	350	0.28	250	0.22	250
	2.0	**	-	0.35	350	0.31	250	0.25	250	0.21	250
20	1.0	**	-	0.46	-	0.42	-	0.34	300	0.27	250
	1.5	**	-	0.41	-	0.36	300	0.29	250	0.23	250
	2.0	**	-	0.36	300	0.32	250	0.26	250	0.22	250
24	1.0	**	-	0.49	-	0.44	-	0.37	250	0.26	200
	1.5	**	-	0.44	-	0.38	300	0.31	200	0.24	200
	2.0	**	-	0.39	300	0.34	250	0.27	200	0.23	200
30	1.0	**	-	0.53	-	0.46	350	0.41	250	0.27	150
	1.5	**	-	0.48	350	0.41	250	0.34	150	0.25	150
	2.0	**	-	0.43	300	0.37	200	0.30	150	0.24	150
36	1.0	**	-	0.56	350	0.48	300	0.40	200	0.28	150
	1.5	**	-	0.51	300	0.43	250	0.33	150	0.27	150
	2.0	**	-	0.46	250	0.40	200	0.31	150	0.26	150
42	1.0	**	-	0.58	350	0.50	250	0.39	150	0.29	150
	1.5	**	-	0.54	300	0.45	200	0.35	150	0.28	150
	2.0	**	-	0.49	250	0.42	200	0.33	150	0.27	150
48	1.0	**	-	0.60	300	0.52	200	0.39	150	0.31	150
	1.5	**	-	0.57	250	0.48	200	0.37	150	0.30	150
	2.0	**	-	0.53	250	0.45	150	0.36	150	0.29	150
54	1.0	**	-	0.64	250	0.53	200	0.41	150	0.33	150
	1.5	**	-	0.60	250	0.51	150	0.40	150	0.32	150
	2.0	**	-	0.57	200	0.48	150	0.39	150	0.31	150
60	1.0	**	-	0.65	250	0.54	150	0.42	150	0.33	150
	1.5	**	-	0.61	200	0.52	150	0.41	150	0.33	150
	2.0	**	-	0.58	200	0.50	150	0.40	150	0.32	150
64	1.0	**	-	0.66	250	0.55	150	0.43	150	0.34	150
	1.5	**	-	0.62	200	0.53	150	0.42	150	0.33	150
	2.0	**	-	0.59	200	0.51	150	0.41	150	0.32	150

\* Total calculated thickness includes service allowance and casting tolerance added to net thickness.

\*\*For pipe 14-inch and larger, consideration should be given to laying conditions other than Type 1.



## DIPRA MEMBER COMPANIES

American Cast Iron Pipe Company  
P.O. Box 2727  
Birmingham, Alabama 35202-2727

Atlantic States Cast Iron Pipe Company  
183 Sitgreaves Street  
Phillipsburg, New Jersey 08865-3000

Canada Pipe Company, Ltd.  
1757 Burlington Street East  
Hamilton, Ontario L8N 3R5 Canada

Clow Water Systems Company  
P.O. Box 6001  
Coshocton, Ohio 43812-6001

Griffin Pipe Products Co.  
1400 Opus Place, Suite 700  
Downers Grove, Illinois 60515-5707

McWane Cast Iron Pipe Company  
1201 Vanderbilt Road  
Birmingham, Alabama 35234

Pacific States Cast Iron Pipe Company  
P.O. Box 1219  
Provo, Utah 84603-1219

# DUCTILE IRON PIPE

RESEARCH ASSOCIATION



An association of quality producers dedicated to highest pipe standards through a program of continuing research.  
245 Riverchase Parkway East, Suite O  
Birmingham, Alabama 35244-1856  
Telephone 205 402-8700 FAX 205 402-8730  
<http://www.dipra.org>

**DUCTILE IRON PIPE** THE RIGHT DECISION



Manufactured from recycled materials.